

- (12) The reason for using Agar in culture medium which is used in tissue culture;
- 1) To provide nutrients
 - 2) To solidify the medium
 - 3) To increase the cell division
 - 4) To obtain identical clones
- (13) Amal's skin is dry and blisters have appeared on his knee and elbows. Further Bito spots are in his eyes. From which of the following deficiencies of Vitamins is he suffering?
- 1) Vitamin A
 - 2) Vitamin B
 - 3) Vitamin C
 - 4) Vitamin D
- (14) What is the wave length and the amplitude of the wave shown by the diagram?

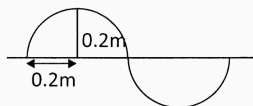

- 1) 0.2m, 0.2m
 - 2) 0.4m, 0.1m
 - 3) 0.8m, 0.4m
 - 4) 0.8m, 0.2m
- (15) How many autosomal pair of chromosomes does a human possess?
- 1) 1 pair
 - 2) 22 pairs
 - 3) 23 pairs
 - 4) 46 pairs
- (16) The object given below maintains the equilibrium under the action of three parallel forces. Select the correct relationship of three parallel forces.

- 1) $F_1 + F_2 > W$
- 2) $F_1 + F_2 = W$
- 3) $F_1 = F_2 = W$
- 4) $F_1 + F_2 = 0$

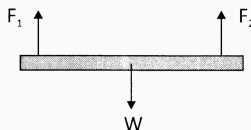

- (17) If 50g of CaCO_3 is heated well how many oxygen atoms are present in the gaseous product?
(Ca = 40, C = 12, O = 16)
- 1) 1.8066×10^{23}
 - 2) 3.011×10^{13}
 - 3) 6.022×10^{23}
 - 4) 7.2044×10^{24}
- (18) 60N load and W load are kept on each corners of a plank in a horizontal configuration as shown in the diagram. What can be the values for distance X and load W respectively?
- 1) 14cm, 120N
 - 2) 48N, 12N
 - 3) 10cm, 48N
 - 4) 64cm, 120N

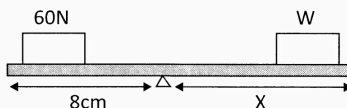

(19) Red - green colour blindness is an inherited disease. Select the correct genotype of a carrier female.

- 1) $X^c X^c$ 2) $X^0 X^0$ 3) $X^c X^0$ 4) $X^c Y$

(20) Photosynthetic plants can't be seen in the sea at a depth about 100m. The main reason for this is.

- 1) Reduction of oxygen 2) Increase of Carbondioxide
3) Less light intensity 4) Low temperature

(21) Find the temperature of 800g of aluminum at a temperature 32°C when 28800J of heat is transferred to it? (Specific heat capacity of aluminum is $900\text{Jkg}^{-1}\text{K}^{-1}$)

- 1) 40°C 2) 72°C 3) 8°C 4) 100°C

(22) Select the suitable energy level diagram for photosynthesis process happening in green plants.

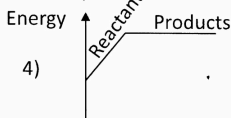
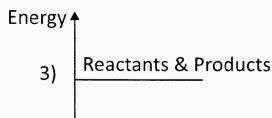
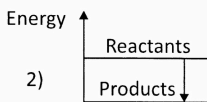
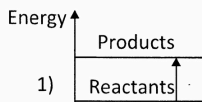

(23) The separation of components in a mixture can be done using different methods. What is the method used to separate the components 1 shown in the above diagram?

- 1) Filtration 2) Crystallization
3) Solvent extraction 4) Simple distillation

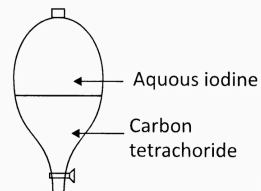

(24) What is the work done in 2 minutes by a machine operating with a power output of 150W?

- 1) 9KJ 2) 900J 3) 1800J 4) 18KJ

(25) Select the occation of diffusion from following,

- A - Exchange of gases in the wall of alveoli
- B - Supplying glucose to body tissues from blood.
- C - Double circulation of blood

- 1) A and Only 2) A and B only
3) B and Only 3) A, B, Call

(26) Given below is a displacement - time graph of a motion of an object.

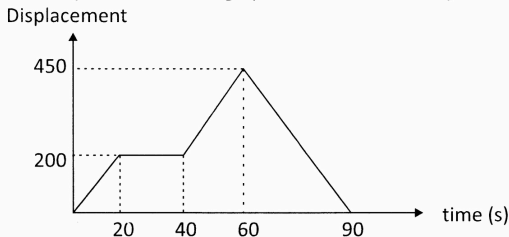

Select the correct velocity - time graph for the above motion.

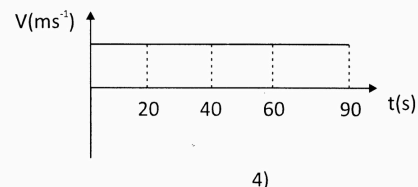
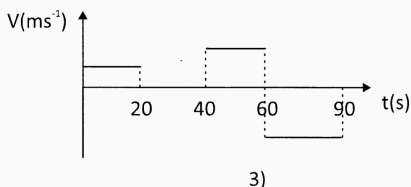
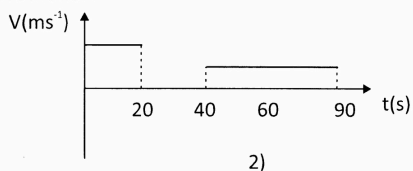
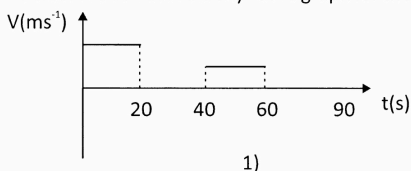

(27) The gas which is used for production of margarine from vegetable oils is

- | | |
|-----------------|----------------------|
| 1) Oxygen gas | 2) Hydrogen gas |
| 3) Nitrogen gas | 4) Carbondioxide gas |

(28) Which of the following phenomena agrees most with Newton's third law of motion?

- 1) A ball falling down from a higher level bounces after touching the ground.
- 2) The velocity of fruit falling from a tree reaches the maximum value when it touches the ground.
- 3) When a moving bus suddenly stops by applying brakes the passenger who is standing on a moving bus without holding anything for support falls towards the forward direction.
- 4) Changing the direction of a moving football by kicking it.

(29) Select the correct observation and the reason for the observation for the activity done to examine the effect of other metals on corrosion of iron.

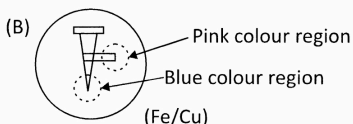
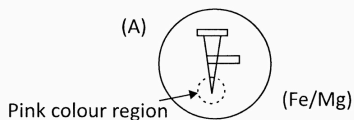

Observation

Reason

- | | |
|---|---|
| 1) Appearance of pink colour around the iron nail in set up A | Formation of Fe^{2+} ion around iron nail |
| 2) Appearance of pink colour around the Cu strip in set up B | Formation of Cu^{2+} ion around iron nail |
| 3) Appearance of blue colour around the iron nail in set up B | Formation of OH^- ion around iron nail |
| 4) Appearance of pink colour around the Cu strip in set up B | Formation of OH^- ion around Cu strip |

(30) The following velocity-time graph illustrates motion of an object during 60s. Consider the statements given below regarding motion.

- A - The object has moved at uniform deceleration within 60s.
 B - The objects displacement within initial 60s is 240m
 C - The acceleration of the object uniformly decreased with the time.

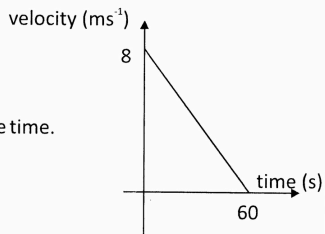

The correct statements are;

- | | |
|-----------------|-----------------|
| 1) A and B only | 2) A and C only |
| 3) B and C only | 4) A, B, C all |
- (31) Select the incorrect statement from the following.
- Rise in temperature of machines can be minimized by reducing frictional forces.
 - The limiting frictional force is directly proportional with the normal reaction.
 - The limiting frictional force does not depend on the nature of the surfaces in contact.
 - The limiting frictional force does not depend on the surface area.

(32) Select the amphoteric oxide from the following.

- | | | | |
|----------------|------------|------------|--------------|
| 1) Cl_2O_7 , | 2) Na_2O | 3) SiO_2 | 4) Al_2O_3 |
|----------------|------------|------------|--------------|

(33) What is the hormone which influence on releasing ovum into the fallopian tube?

- | | |
|-----------------|--------------|
| 1) Testosterone | 2) FSH |
| 3) LH | 4) Oestrogen |

(34) If the strip moves to the right. What are the suitable values for A, B and C respectively.

- 3N, 7N, 2N
- 4N, 7N, 6N
- 7N, 14N, 7N
- 0N, 5N, 5N

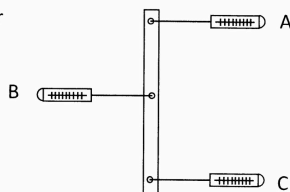

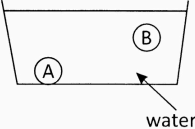
- (35) Select a polarized molecule from the following molecules.
- 1) Hydrogen molecule
 - 2) Carbon dioxide molecule
 - 3) Oxygen molecule
 - 4) Hydrogen fluoride molecule
- (36) What is the acid used for coagulation of rubber latex?
- 1) Nitric acid
 - 2) Hydrochloric acid
 - 3) Sulphuric acid
 - 4) Acetic acid
- (37) Location of two equal volume objects A and B in a water trough is shown below. Select the correct statement.
- 1) Upthrust exerted on A is more than the upthrust exerted on B.
 - 2) Densities of A and B objects are equal.
 - 3) Mass of A and B objects are equal
 - 4) The volume of water displaced by A and B objects are equal.
- 
- (38) The diameter of a mango tree is increased with the growth of the mango tree. What is the tissue responsible for the above mentioned growth.
- 1) Phloem tissue
 - 2) Cambium
 - 3) Collenchyma
 - 4) Sclerenchyma
- (39) When a stone with a mass of 500g is moving at a velocity of 10ms^{-1} . The kinetic energy of it is;
- 1) 2.5J
 - 2) 5J
 - 3) 25J
 - 4) 25000J
- (40) The aim of shortening the food mileage is;
- 1) To direct people more to consume native food
 - 2) To get an opportunity to consume quality food
 - 3) To create a greater demand for the locally produced food.
 - 4) To minimize the amount of fuel spent during transport of food.



Royal College - Colombo 07

රාජකීය විද්‍යාලය - කොළඹ 07

Third Term Test - (January 2025)

අවසාන වාර පරීක්ෂණය - (ජනවාරි 2025)

කාලය : 03
Time : 03

ශ්‍රේණිය } 11
Grade } 11

Science

විද්‍යාව

34 E II

Name :-Class:Index No :-

Paper II

- ❖ Write the answers in clear hand writing.
- ❖ Write answers for part A in the space provided on the paper itself.
- ❖ Answer only three from the given questions in Part B.
- ❖ Attach and handover the answer sheets of part A and Part B together after writing.

Part A

(01)(A) Consumption of energy sources during 180 years over the Earth has been illustrated in the given figure.

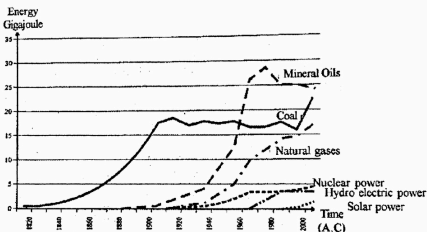

- i) Which energy source is used in maximum level to produce energy?
.....
- ii) Which energy source had been used in ancient time as the energy source?
.....
- iii) Write 2 harmful gasses emitted by using above energy source.
1)
2)
- iv) Write two environmental problems that may arise due to the emission of above two gases.
1)
2)

v) Write two regenerative energy forms from the above graph?

- 1)
- 2)

vi) Name 2 elements used as nuclear fuel.

- 1)
- 2)

(B) Fixation of atmospheric Nitrogen keep the equilibrium of Nitrogen cycle by the processes, nitrification, denitrification, and ammonification. The following figure illustrate Nitrogen cycle.

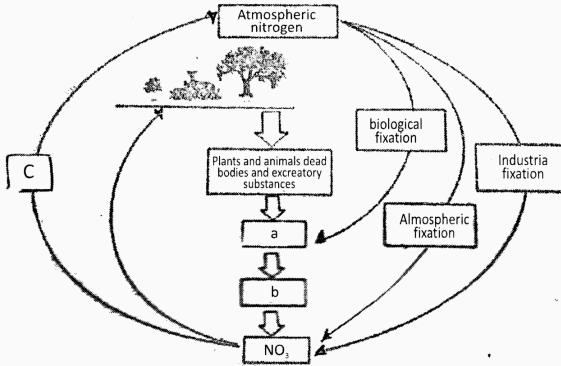

i) Identify the substances labeled as (a) and (b)

- a -
- b -

ii) Name the natural process which carry out the atmospheric fixation.

.....

iii) Name two organisms which involves in biological fixation.

- 1)
- 2)

iv) Write the suitable word for space C.

.....

v) Write two ways in which element Nitrogen exists in animal and plant bodies.

- 1)
- 2)

(C) A graphical representation of energy pyramid is given below.

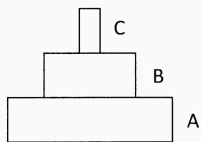

i) What is an energy pyramid?

.....

ii) Write 3 organisms suitable for A, B and C levels.

A -

B -

C -

iii) State the reason for energy pyramids always being upward pyramids.

.....

iv) Write two ways by which the energy get wasted from the bodies of organisms.

1)

2)

(15 Marks)

(02)(A) A group of students arranged the following set up for a practical session. They used two set ups as experimental set up and control set up, to show the effect of one factor for photosynthesis.

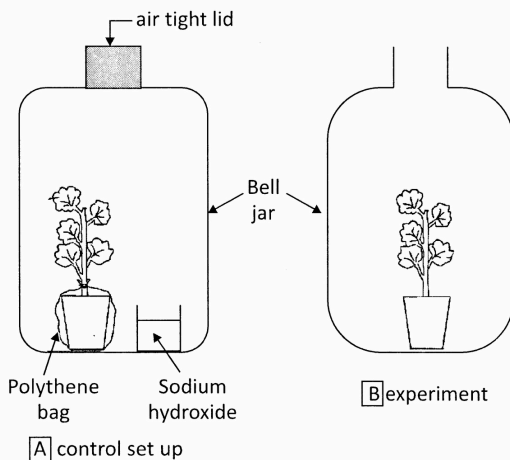

- i) Write the factor that this group of students try to find whether it is necessary for photosynthesis.
.....
- ii) What is the purpose of using Sodium hydroxide in the set up A.
.....
- iii) What is the aim of using a control set up for this experiment.
.....
- iv) Write two factors that should be kept constant during this activity.
1)
2)
- v) Write one step that should be essentially done before setting up the apparatus.
.....

(B) Few organs related to digestive system are given in the following figure.

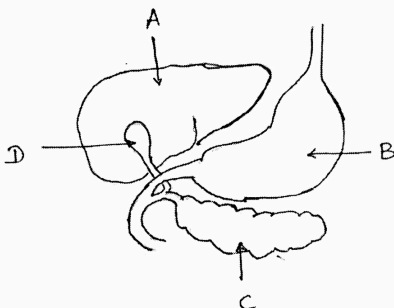

- i) Name the organs.
A -
B -
C -
D -
- ii) Name an enzyme and hormone secreted by the organ C.
enzyme -
hormon -
- iii) Juices secreted by organ B contains an acid. Name the acid and function of it.
acid
function
- iv) Which nutrient in food get digested in the organ B.
.....

(C) A group of students observed following organisms during their field visit in a rain forest.
(Lizard, Cockroach, Frog, Seleginella, Leech, Snake, Cycas, Coconut)

- i) Name the organism which contain internally and externally segmented body.
.....
- ii) Write one more feature that is seen in the above organism.
.....
- iii) Which organism belongs to the group which respire through skin.
.....
- iv) Write one difference between cycas and selaginella plants.
.....
.....
- v) Write two features of the animal group that snake belongs.
1).....
2).....

(15 Marks)

(03) (A) Description about 4 elements out of first 20 elements in the periodic table are shown below.
Symbols used are not standard symbols. Answer the questions only using given symbols.

- L - Lightest element which has a completed valance shell.
- M - Become stable by making unipositive ion. Has the lowest first ionization energy.
- Q - Naturally occurs as diatomic gas. It occupies 20% of the atmosphere.
- R - Possesses the hardest allotrophic form, that exists naturally other form used for making electrodes.

- i) Identify L, M, Q and R and name them.
L - Q -
M - R -
- ii) Show in an ionic equation how an atom of M becomes a univalent positive ion.
.....
- iii) Write the formula of the compound made by the reaction between M and Q
.....
- iv) Draw the lewis structure of the molecule made by the reaction between Q and R.
.....
.....

(B) A figure of a chemical bond formation of a particular compound is given below.

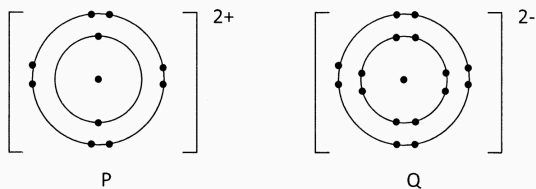

- i) What is the bond type of this chemical compound.
.....
- ii) Write the number of protons and electrons in the ion Q after forming the bond.
electrons -
protons -
- iii) Name the above chemical compound.
.....
- iv) Write two chemical properties of the above chemical compound.
.....
.....

(C) Some example of changes of matter are given below.

- a - Melting of ice.
 - b - Heating potassium permanganate
 - c - Adding magnesium to dilute hydrochloric acid.
 - d - Sending Carbon dioxide gas through lime water
- i) One change of matter is different from others. State that difference.
.....
 - ii) Write down the balance chemical equation for d.
.....
 - iii) Which type of chemical reaction is C?
.....
 - iv) Which gas is emitted during the reaction b?
.....

(15 Marks)

- (04) (A) A student saw his image smaller behind the mirror when he used a certain mirror to see his face.
- i) What is the type of mirror used by the student.
.....
 - ii) Mention two other features that he could see in the image formed on the mirror.
.....
.....

iii) Draw the ray diagram to represent above incident.

iv) The path of light rays change when they enter from water to air (Critical angle of water is 49°)
Complete the ray diagrams given below.

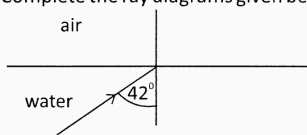

(A)

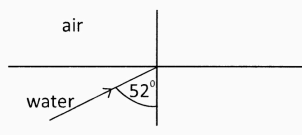

(B)

v) Write the equation for finding refractive index.

.....

vi) Refractive angle is found as 62° in the above instance (A). If $\sin 42^\circ = 0.669$ and $\sin 62^\circ = 0.882$, find the refractive index of water relative to air.

.....
.....
.....

(B) The diagram of electric circuit is shown below.

It consist of four resistors each of $R\Omega$ (internal resistance of the battery is negligible)

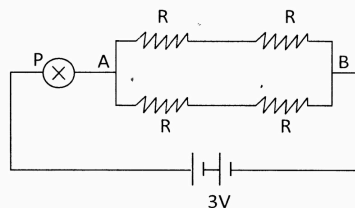

i) Write an expression for equivalent resistance of the resistors used in the circuit in terms of R.

.....

ii) When 0.2A current flows through the bulb P the potential difference between the two terminals of the bulb is 2V. Then calculate the resistance of fillament bulb.

.....
.....
.....

iii) What us the potential difference between the points A and B.

.....
.....
.....

iv) Find the value of resistance of one resistor (R)

.....
.....

(15 Marks)

Part B

(05) (A) The following graph represents the volume of urine and sweat produced during one hour by a healthy person. (The unit used to measure the value of sweat and urine is cubic centimeters per hour cm^3/h)

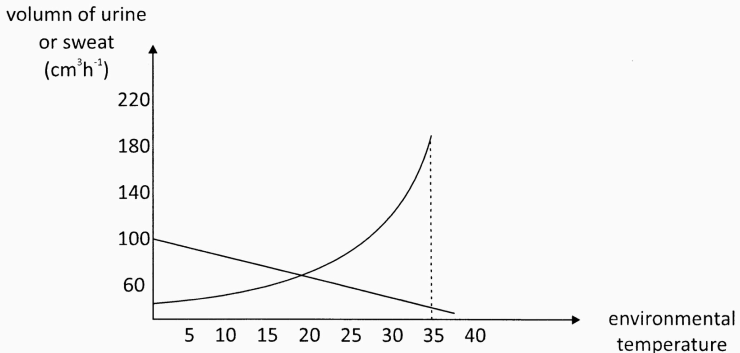

- i) How does the amount of urine and sweat production varies with environmental temperature.
- ii) How does homeostasis activates when the water content in the body decreases.
- iii) Name the process of filtration of blood plasma through bowman's capsule in a nephron.
- iv) State briefly what is nephritis.
- v) Name the organ which perform the both endocrine and exocrine processes.

(B) The following chart represents colour of iris of children borne to mixed marriage (Tamil & Sinhala)

◇ Brown iris colour is the dominant gene.

◇ Blue iris colour is the resessive gene.

Circles in the chart represent females and squires represent boys.

(Genotypes of Chanuki and Himas are equal)

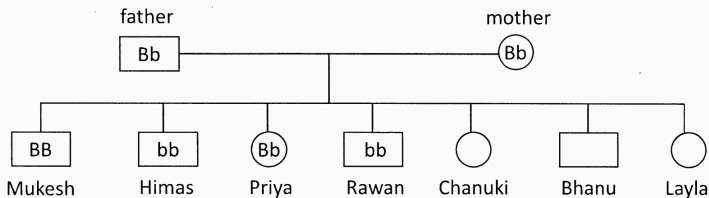

- i) Write the names of children having brown eyes.
- ii) Write the genotype and phenotype responsible for eye colour of Rawan.
- iii) Which one may be the identical twin brother/sister of Priya?

iv) Mukesh married a girl whose eye colour was purebred Blue. Draw a punnet square to represent the eye colour of their children.

(C) A rough sketch which represents human reproduction is given below.

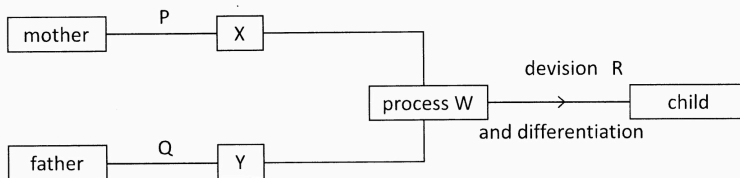

Write answers according to the above chart (X and Y are gametes)

- i) Write the difference between cell division methods P, Q and R/
- ii) Which gametes are represented by X and Y.
- iii) Write the organ which produce gamete X and Organ which produce the hormone that stimulate this organ separately.
- iv) The hormone which is important to produce Y control the appearing of secondary sexual characteristics of males. Which structure produces this hormone.
- v) Where does the process W takes place in the female reproductive system.
- vi) Which hormone in blood declines, if the process W doesn't occur between X and Y in the female reproductive system?
- vii) Name one substance for each which exchange and does not exchange between mothe's and foetu's blood?
- viii) Name a disease which is sexually transmited and caused by a bacterium?

(20 Marks)

(06) (A) The given figure represents the change of pH value when potassium hydroxide solution is added dropwise in to a solution of hydrochloric acid. Volume of hydrochloric acid used here is 20cm^3 and its concentration is 0.2mol dm^{-3} .

Volume of potassium hydroxide (cm^3)	0	20	40
pH value of solution	1	7	14

- i) Write the balanced equation for the reaction between potassium hydroxide and hydrochloric acid.
- ii) Calculate the hydrochloric acid moles in the above solution.
- iii) Find the amount of potassium hydroxide acid moles that reacted with above amount in (ii)
- iv) What can you say about the amount of acid and base in the mixture when the pH value is 7
- v) Define what nutralization is

(B)

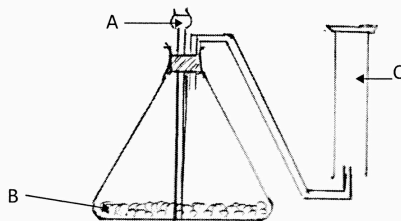

The above setup prepared for collecting a gas sample used for the production of margarine.

- i) Name the chemical substances A, B.
- ii) What is the gas C.
- iii) State the gas collection method shown in the figure.
- iv) Which property of the gas is used for collecting it by above method.
- v) Name the bond type of H_2 molecule.
- vi) Draw the lewis structure of the molecule formed by the reaction of N and H.

(C) Few metals of the activity series are given below.

Mg, Cu, Zn, Ca, Fe, Al

- i) Arrange the above metals in ascending order of reactivity.
- ii) Which metal tarnishes quickly when exposed to atmosphere.
- iii) State the reason for tarnishing of metals.
- iv) Which metal do not react with dil hydrochloric acid.
- v) Which metal reacts with hot water without reacting with cold water.
- vi) If few drops of phenolphthaline is added to the solution formed after the above reaction, what will be the colour change.
- vii) Write the extracting methods of Al and Zn.

(20 Marks)

(07) (A) Following diagram illustrates the hydro power generation and transmission through the National grid of Sri Lanka.

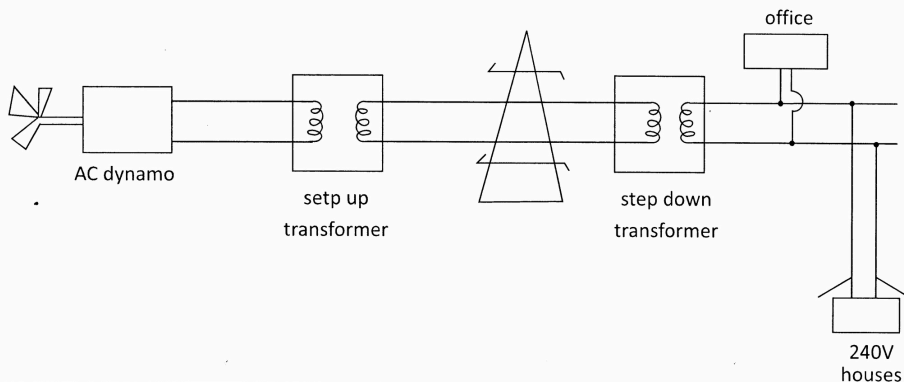

- i) Write down the energy transformation in a hydro power plant.
- ii) What is the reason for the transmission of alternating current (ac) instead of direct current (dc)?
- iii) Explain the reason for the transmission of current using high voltage differences.
- iv) Which device is used to increase the voltage difference in the power supply?
- v) A domestic user of electricity connects the following heating element to the house hold circuit through a three-pin plug.

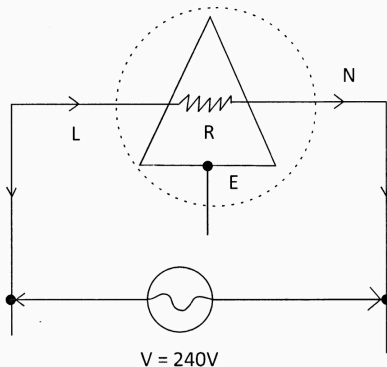

- a) Power of the above appliance is 1000W. Calculate the current passing through it.
 - b) Write down an appliance in the circuit that protects the domestic user.
 - c) Write down one safety precaution when handling electricity at home.
- (B) Following arrangement was used to convert the alternating current into direct current in an ac-dc adaptor.

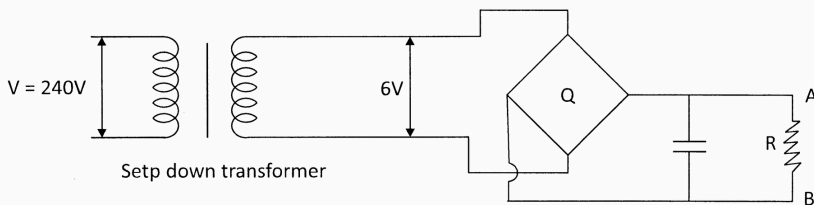

- i) Draw the arrangement of four rectifying diodes in the part Q of the above arrangement, using circuit symbols.
- ii) Draw the graph for out put produced at the terminals A and B.
- iii) Name the accessory used to smooth the current.
- iv) The out put voltage difference produced by the above apparatus was connected with two terminals of the coil ABCD which is in between the two poles of a magnet.

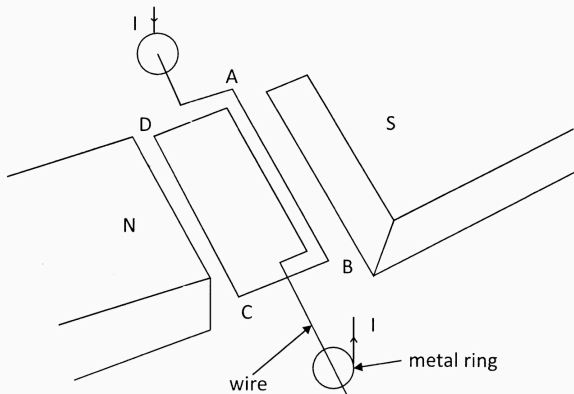

- State the direction of the force on the side AB
- Mention the law you used to find the above factor.
- One half of the coating of the wire that rotates within the metal ring was removed.

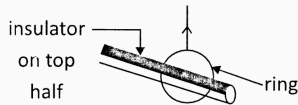

What is the requirement of this arrangement?

- Step-down transformer connected to Q produces a voltage difference of 6V when connected with 240V. Calculate ratio between $N_p : N_s$ in it.

(20 Marks)

(08) (A) The figure shows some organs and blood vessels associated with the human body.

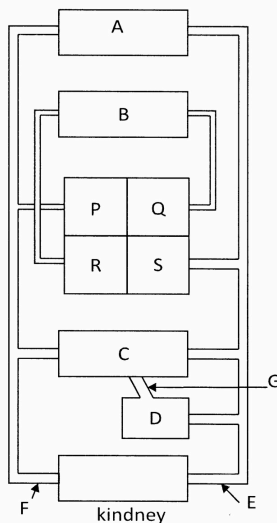

- i) Name the organ which is represented as A and B.
 - ii) Name the chamber which matches with the given description.
 - a) Deoxygenated blood received from body.
 - b) Walls are very thick to pump blood to body.
 - c) Receives blood with more oxygen
 - d) Pump blood to lungs.
 - iii) Name the blood vessel denoted as G.
 - iv) State the function of blood vessel mentioned above.
 - v) State one difference between the composition of blood in the vesseles E and F.
 - vi) Write two functions performed by the organ C.
 - vii) Name the artery which pump blood for heart muscles.
 - viii) Write one heart disease and a reason for the disease.
 - ix) Write two health habits to minimize heart diseases.
- (B) In the figure (1), a light plank on two trestles is supporting a man and a block of concrete.

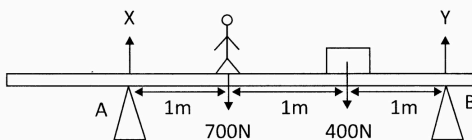

- i) Turning effect of a force (moment) depend on two factors. What are they.
 - ii) Write down the moment of each force about A.
 - iii) If the above set up is in equilibrium write an expression for the moments around A.
 - iv) Calculate the reaction force Y using the above equation.
 - v) What is the total upward force on the light plank.
 - vi) Calculate the magnitude of the reaction force X.
- (C) In the figure (2) the man walks past A towards the end of the plank.

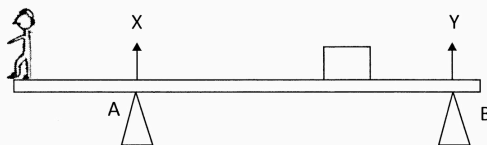

- i) What is the reaction force Y at the instant the plank starts to tip?
- ii) How far is the man from A as the plank starts to tip.
- iii) What is the moment of couple of forces in the following figure.

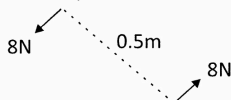

(20 Marks)

- (09) (A) The figure represents a structure of a solar water heater. There is a tube system made up of copper with 7m long inside the section which absorb solar heat. That part has made air tight and coloured with black. The top surface has covered with thin glass sheet.

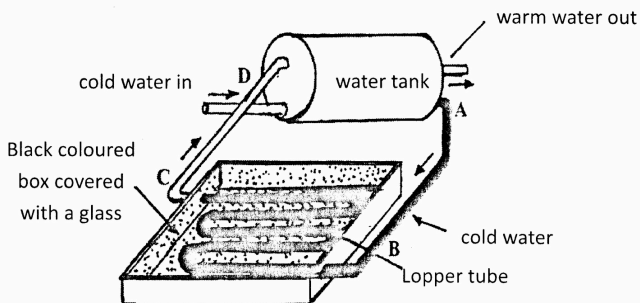

- i) State the reason for making the tube system with copper.
- ii) Write the advantage of colouring the tubes with black paint.
- iii) Name the method by which this equipment receive heat.
- iv) Specifications of the above solar heater is given as follows.
 - ◇ The total energy received by the heater in a sunny day - 126000kJ
 - ◇ Efficiency of the heater - 20%
 Find the amount of heat energy can be obtained by this heater in a sunny day.
- v) If water is heated from 30°C to 70°C using this heater, calculate the mass of water can be heated during one day. (Specific heat capacity of water is 4200Jkg⁻¹k⁻¹)
- vi) Calculate the electrical units saved by the consumer by using this heater during a month. (Energy amount in one electrical unit is 3600kJ)

- (B) Following figure shows an experimental set up to produce electricity.

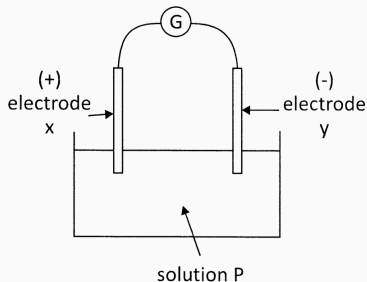

- i) Name the suitable metals to use as electrode X and Y.
- ii) Name the solution P.

- iii) Write the half reactions occur at (+) and (-) electrodes respectively.
 - iv) Name the anode and cathode of the cell.
 - v) Write two observations of this activity.
 - vi) Write the current flowing direction of the above cell.
- (C) Average petrol blend contains around 150 different hydrocarbons. One of it is Pentane.
- i) Write the chemical formula of Pentane.
 - ii) To which hydrocarbon category Pentane belongs?
 - iii) Write the balance equation for the complete combustion of Pentane.

(20 Marks)